

## Power roof ventilator MIRUVENT, version 3 Installation and Maintenance Instructions

---

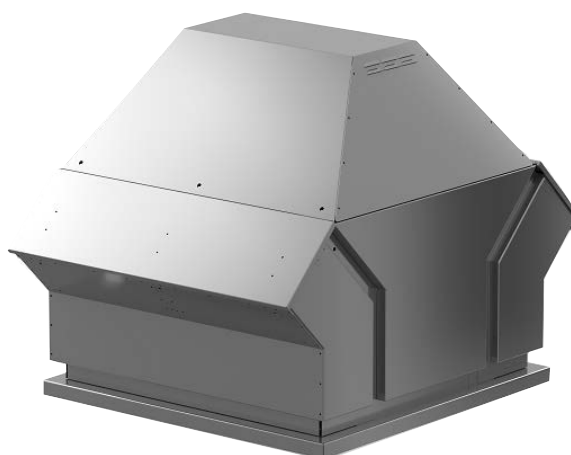

## 1. Safety Instructions

All staff concerned must acquaint themselves with these instructions before beginning any work on the power roof ventilator. Any damages to the power roof ventilator or parts of it due to improper handling or misuse by the purchaser or the fitter cannot be considered subject to guarantee if these instructions have not been followed correctly.



### Warning

Only a qualified electrician or service personnel trained by Swegon are permitted to carry out any work on the power roof ventilator in connection with the electrical installation.

#### 1.1 Safety Isolating Switch/Main Switch

The safety isolating switch is located on the power roof ventilator's cover.

Always switch off the safety isolating switch before servicing.

#### 1.2 Risks

### Warning



Before carrying out any work, make sure that the power supply to the power roof ventilator has been switched off. Risk of personal injury!

#### Risk areas with moving parts

Moving parts are fan impellers and airstream operated damper.

### Warning



Wait until the fan has stopped before starting any work. Wait until hot surfaces have cooled. Refit all parts that have been dismantled before starting. Risk of personal injury!

#### Raise/lower the power roof ventilator

The power roof ventilator can be raised for inspection and maintenance.

### Warning



Make sure the power roof ventilator does not suddenly move back to the raised position. Risk of personal injury!

#### 1.3 Safety Guards

The power roof ventilator is delivered without contact guard for the fan inlet. If there is a risk of contact with the impeller, depending on the installation method, a contact guard (wire mesh) must be fitted.

## 2. General

### 2.1 Range of Application

The MIRUVENT is an extract air fan, designed for use in most systems in comfort ventilation systems, in which the air has a low content of impurities and does not contain aggressive gases and vapours.

The power roof ventilator should preferably be mounted on an LBFT roof penetration collar. This provides a fire-resistant and sound-absorbent extraction passage through the roof and a tight connection to the extract air duct. As an alternative the power roof ventilator can be mounted on an existing roof penetration collar across a TBFS connection fitting.

The power roof ventilator is can be raised, which facilitates inspection and cleaning of both the fan and extract air duct.



### Important!

Always read the safety instructions in Section 1 that explain the risks involved in running the unit and designate who shall be permitted to operate and service the unit, and carefully follow the installation instructions provided in each paragraph.

The product identification plate is located on the outside of the power roof ventilator. Refer to the particulars on the product identification plate when you contact Swegon.

Power roof ventilator, type	Swegon's designation
RDM 3S-2528-BI-TT-L	MIRU-3-25-28-1-1
RDM 3S-2531-BI-TT-L	MIRU-3-25-31-1-1
RDM 3S-3535-BI-TT-L	MIRU-3-35-35-1-1
RDM 3S-3540-BI-TV-L	MIRU-3-35-40-1-1
RDM 3S-3545-BI-TW-L	MIRU-3-35-45-1-1
RDM 3S-4550-BI-TX-L	MIRU-3-45-50-1-1
RDM 3S-4556-BI-1W-L	MIRU-3-45-56-1-1
RDM 3S-4556-BI-UW-L	MIRU-3-45-56-2-1
RDM 3S-5663-BI-1W-L	MIRU-3-56-63-1-1
RDM FS-5671-BI-2U-L	MIRU-3-56-71-1-2
RDM FS-7180-BI-2U-L	MIRU-3-71-80-1-2
RDM FS-7180-BI-2Y-L	MIRU-3-71-80-2-2
RDM FS-7190-BI-3S-L	MIRU-3-71-90-1-2

### 2.2 Mechanical Design

The power roof ventilator is available in 5 physical sizes with 13 different airflow variants up to 30,600 m<sup>3</sup>/h.

Upward air stream with a long throw length protects the roof from fouling.

Closed, discretely designed casing made of corrosion-resistant aluminium, Environment class C4.

The load-bearing design is made of galvanized sheet steel for mounting a connecting sleeve, with wide overhang for accommodating the connection fitting insulation.

Outlet openings covered with self-opening and self-closing airstream-operated dampers as protection against bad weather when the fan is idle. The airstream-operated dampers also counteract heat losses.

The sections of the casing and the fan impeller with motor are easy to dismantle for inspection and maintenance.

The electric equipment conforms to the provisions of the EMC Directive and is tested according to EN 61000-6-2 and EN 61000-6-3 Standards (radiation in homes, offices, shops and similar environments as well as for immunity in industrial environments).

### Fan insert

Highly efficient EC-motors with integrated motor control in efficiency class IE4.

Radial impeller with backwards inclined blades. Completely maintenance-free, vibration-free mounted motor with motor control. The motor is cooled with separate cooling air.

Min. exhaust air temperature -20 °C, max. exhaust air temperature +60 °C when operating continuously.

Max. ambient temperature +40°C.

## 3. Installation

### 3.1 Packaging

The power roof ventilator is supplied prepacked in a sturdy carton or on a pallet depending on the size and weight. The power roof ventilator must be handled with care and upright (see arrows on the packaging) as well as kept dry.

### 3.2 Storage

Store the power roof ventilator, in its packaging, in a well-ventilated area with a non-corrosive environment, at temperatures from -20 °C to +40 °C and max. 70% relative humidity.

### 3.3 Transport

#### Warning!



Only use inspected and suitable lifting devices (see rating plate).

Only lift the power roof ventilator from the base frame and/or lifting eyes.

Secure the load carefully.

Make sure no one is under the load when lifted. Risk of personal injury!

**NOTE!** The fan can be damaged if lifted from the casing. Always lift the power roof ventilator from the lifting eyes with lifting device and spacer yoke.

Select a means of transport based on the weight and dimensions of the fan.

Lift the fan using the designated lifting points (see the packaging).

Secure the load with e.g. transport straps or anti-slipping devices.

Transport the power roof ventilator carefully and avoid damage from e.g. shocks or hard lowering on its edges.

### 3.4 Preparations

Placement of the power roof ventilator must be appropriate in terms of type, condition, ambient temperature and surrounding medium.

The surface must be flat and have sufficient load-bearing capacity.

Normally the installation site must be horizontal, but installation on inclined surfaces up to 20° is permitted.

**NOTE!** When the power roof ventilator installation is inclined it must be positioned, facing as illustrated.

Right

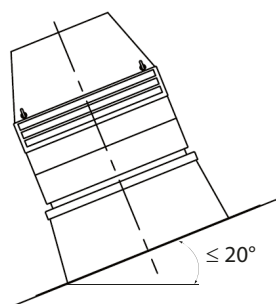

Wrong

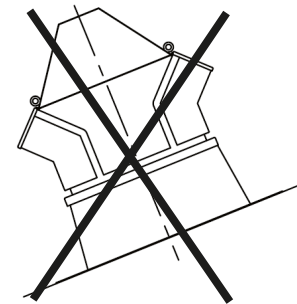

### 3.5 Installation examples

#### TBFT roof penetration collar

1. Outlet openings covered with self-opening and self-closing airstream-operated dampers (standard) as protection against bad weather when the fan is idle. The airstream-operated dampers also counteract cold down draughts and heat loss.
2. MIRUVENT power roof ventilator
3. TBFT roof penetration collar including TBFS connection fitting
4. 50 mm thick insulation conforming to the provisions of Fire-resistance Class EI 30 alt. EI 60, internally lined with perforated sheet steel.
5. Cable protection
6. Structural panel (not supplied by Swegon).
7. Roofing felt, sheet steel or similar weatherproof roofing material (not supplied by Swegon).
8. Pivotal mounting brackets (supplied as separate items).
9. Existing roofing (not supplied by Swegon)

The TBFT roof penetration collar is equipped with slip-clamp profiled sections for connection of a rectangular duct.

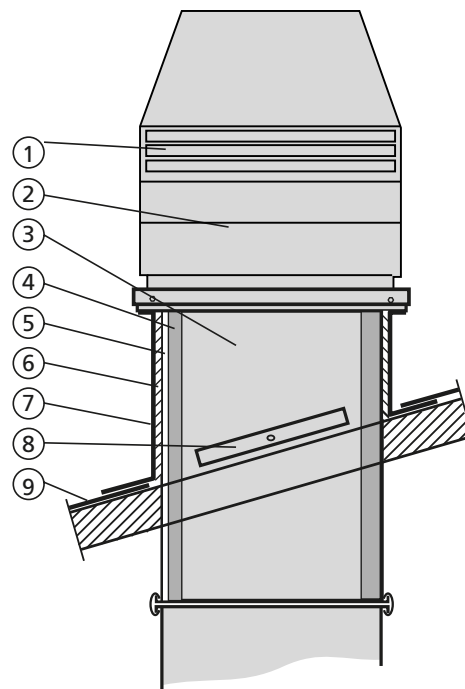

### 3.6 Implementation



#### Warning

Install the power roof ventilator so that its stability is always guaranteed during operation. The installation must be carried out by a professional. Use a flexible connection for duct connection. No forces or vibrations may be transferred to the power roof ventilator fan from the other parts of the installation.

#### 3.6.1 General

The power roof ventilator is primarily designed to mount on the connecting sleeve. If the existing roof penetration collar shall be used, connecting sleeve TBFS is available as an accessory.

The connecting sleeve is included when ordering the TBFT roof penetration collar accessory.

#### 3.6.2 Connecting sleeve TBFS and power roof ventilator MIRUVENT

Connecting sleeve is supplied loose.

The joint between the existing roof penetration collar and the connecting sleeve are sealed using an appropriate sealing strip/sealant (not Swegon). The connecting sleeve is carefully secured in appropriate way in the existing roof penetration collar.

The supplied sealing strip is fitted on the connecting sleeve to seal between the power roof ventilator and the connecting sleeve.

The power roof ventilator is placed above the connecting sleeve and is secured with screws and nuts (not Swegon) using the predrilled fastening holes.

Tighten the screws equally.

Remove the locking screws on the connecting sleeve. Raise the power roof ventilator. Chain/wire mounted on the inside of the connecting sleeve is carefully secured in the roof penetration collar, so that a correct opening angle is obtained (size 25–45).

#### 3.6.3 TBFT roof penetration collar and MIRUVENT power roof ventilator

The connecting sleeve is a part of the TBFT roof penetration collar accessory and is supplied fitted on the roof penetration collar.

The roof penetration collar is mounted using a suitable method, the supplied fastening bracket can be used. Make sure that the support surface is designed to bear the weight of the power roof ventilator.

The supplied sealing strip is fitted on the connecting sleeve to seal between the power roof ventilator and the connecting sleeve.

The power roof ventilator is placed above the connecting sleeve and is secured with screws and nuts (not Swegon) using the predrilled fastening holes.

Tighten the screws equally.

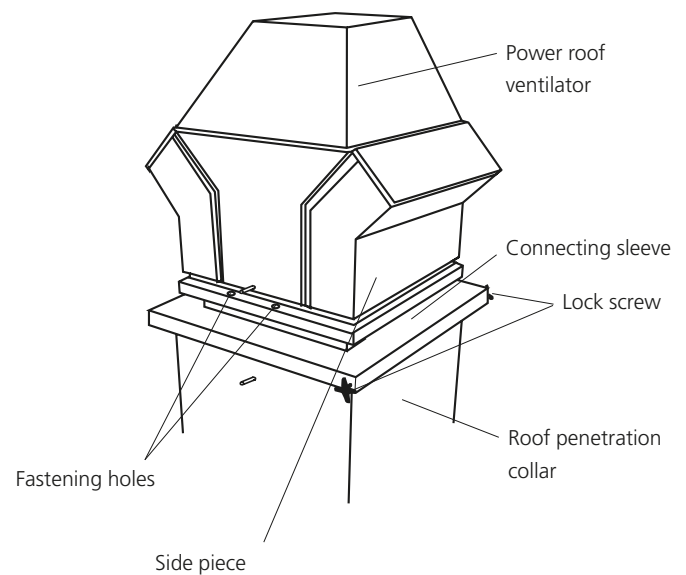

## 4. Electrical connections

### Warning

The electrical connections should be wired by a qualified electrician in accordance with local electrical safety regulations.

Make sure that the safety isolating switch is shutoff and the power cable is not energized.

If the impeller rotates due to natural draught, a generator effect occurs. The impeller should be secured (locked) to prevent this.

Check that the current, voltage and mains frequency correspond with the fan's and motor's rating plate.

### 4.1 Power supply

The connections between the motor, motor controller and safety isolating switch are connected at the factory.

The cable to the power supply is routed through the roof or roof penetration collar's (accessory) cable conduit, on through the power roof ventilator's predrilled holes with rubber cable glands, into the underside of the power roof ventilator and the intermediate plate. Remove the side piece and motor protection housing (see diagram) to access and secure the cable in the pre-fitted cable clips.

The electrical connection is made directly on the safety isolating switch located in the power roof ventilator's motor compartment, see the diagram below. Remove the junction box cover for access.

The safety isolating switch is equipped with a free normally open contact and a free normally closed contact which can be used to externally indicate the position of the switch.

Connection instructions are located on the cover of the safety isolating switch.

In order to conform with current EMC standards and directives, the use of the total system must always be evaluated. This evaluation is the responsibility of the installer.

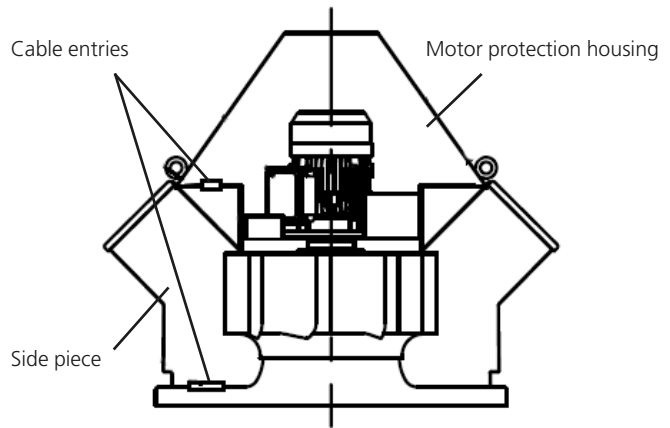

#### 1 × 230 V

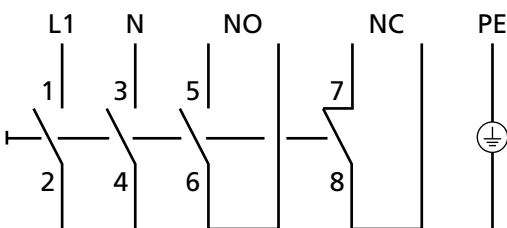

#### 3 × 400 V

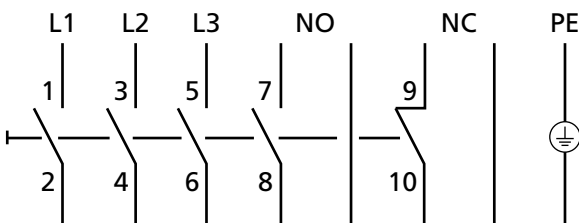

Power roof ventilator, type	Swegon's designation	Rec. fuse*
RDM 3S-2528-BI-TT-L	MIRU-3-25-28-1-1	1 × 10 A
RDM 3S-2531-BI-TT-L	MIRU-3-25-31-1-1	1 × 10 A
RDM 3S-3535-BI-TT-L	MIRU-3-35-35-1-1	1 × 10 A
RDM 3S-3540-BI-TV-L	MIRU-3-35-40-1-1	1 × 10 A
RDM 3S-3545-BI-TW-L	MIRU-3-35-45-1-1	1 × 10 A
RDM 3S-4550-BI-TX-L	MIRU-3-45-50-1-1	3 × 10 A
RDM 3S-4556-BI-1W-L	MIRU-3-45-56-1-1	3 × 10 A
RDM 3S-4556-BI-UW-L	MIRU-3-45-56-2-1	3 × 10 A
RDM 3S-5663-BI-1W-L	MIRU-3-56-63-1-1	3 × 10 A
RDM FS-5671-BI-2U-L	MIRU-3-56-71-1-2	3 × 10 A
RDM FS-7180-BI-2W-L	MIRU-3-71-80-1-2	3 × 10 A
RDM FS-7180-BI-2Y-L	MIRU-3-71-80-2-2	3 × 16 A
RDM FS-7190-BI-3S-L	MIRU-3-71-90-1-2	3 × 16 A

\* Slow burn

**4.2 Control of MIRUVENT power roof ventilator**

MIRUVENT can be controlled directly via GOLD (see function guide MIRUVENT), via fan controller TBMZ-2 (accessory, see installation instruction TBMZ-2) or via external control equipment (see section 4.3).

**4.3 Connecting the motor controller**

Check that the power supply to the motor controller is disconnected before opening the cover.  
 Wait about three minutes after the power supply has been turned off before removing the cover.  
 The cover is removed by loosening the six torx screws that hold the plastic cover in place.

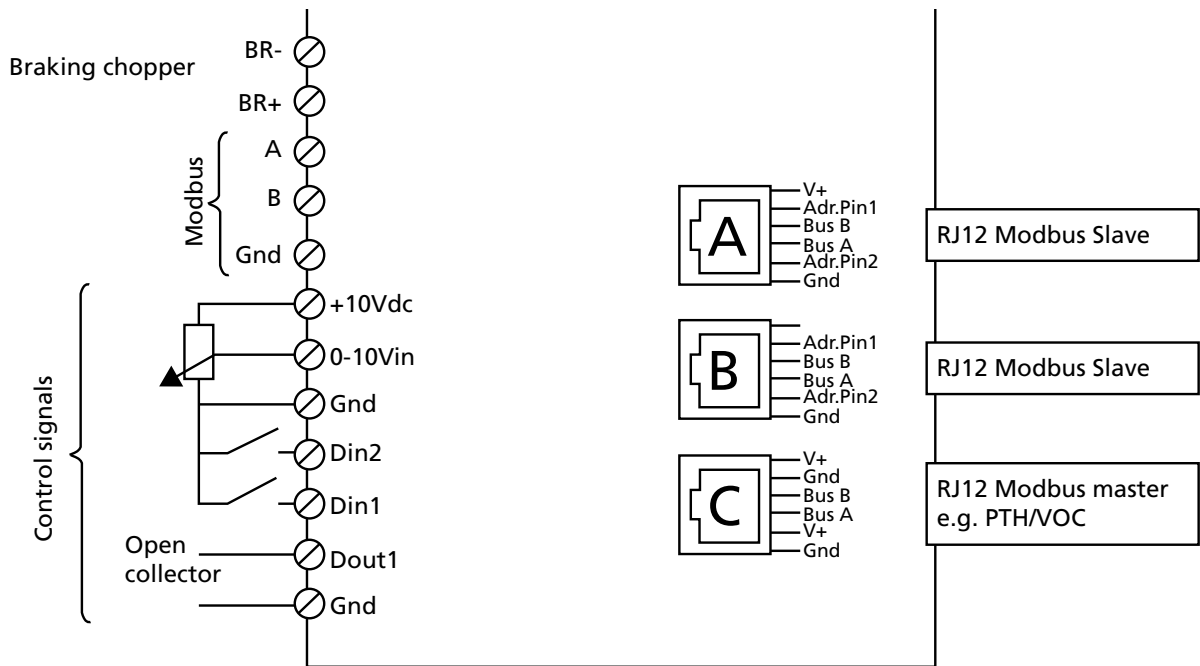

**Modbus connection**

The motor controller is equipped with four connections for Modbus, of which three are RJ12 connectors and one for terminal connection.

The terminals for the Modbus connection are marked "Bus A", "Bus B" and "GND", see above.

The Modbus terminals are connected internally in parallel to the Modbus pins in the RJ12 connections marked "A" and "B".

The three RJ12 connectors are marked "A", "B" and "C".

**"A"**: Modbus connection, slave, +24 V supply voltage in the connection.

**"B"**: Modbus connection, slave, no supply voltage in the connection.

**"C"**: Modbus connection, master, external equipment, for example PTH/VOC sensor.

A 6 core, unshielded, AWG 30/0.066 mm<sup>2</sup> telecommunication cable or similar flat cable for Modbus communication can be used for connection to the three RJ12 connectors.

Connect the RJ12 connectors using a special tool at both ends.

NOTE! The RJ12 connectors must be fitted in such a way that both connectors have the same colour coding as the cable.

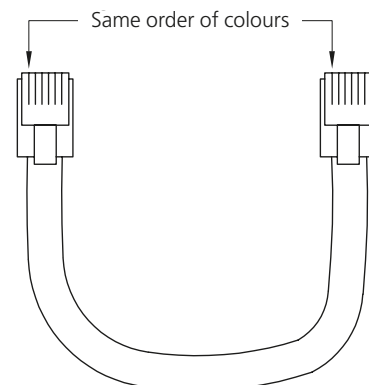

## Connection of control signals

See Figure 1.

+10 V DC = Constant +10 V DC

0–10V in = Analogue 0–10 V control signal for control of the fan speed.

- 0-0.5 V = *Stopped fan*
- 0.5 V = *Min. speed*
- > 9.5 = *Max. speed*

GND = Earth (–)

These three control signals are connected between the motor controller and the enclosure of the safety isolating switch.

## Control via potentiometer

See figure 2 (connection is made in the safety isolating switch enclosure).

Recommended potentiometer 4.7 kΩ, min. 500 Ω.

## External control 0–10 V

See figure 3 (connection is made in the safety isolating switch enclosure).

## Digital inputs/outputs

See figure 4. These inputs/outputs are factory set as shown below. Connection is made on the motor controller's terminal block.

Din1 = Alarm resetting

Din2 = No function

Dout1 = Alarm active Digital output (open collector). Max. pullup voltage +24 V, max. current 20 mA.

If the output is to be connected as a free changeover contact, an auxiliary relay TBLZ-1-85 (accessory) is required or another relay with the equivalent data. See figure 5.

Figure 1

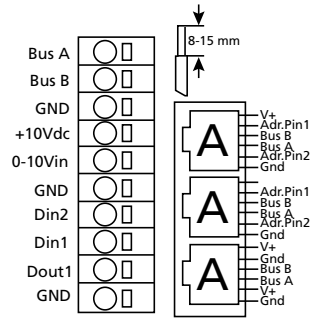

Figure 2

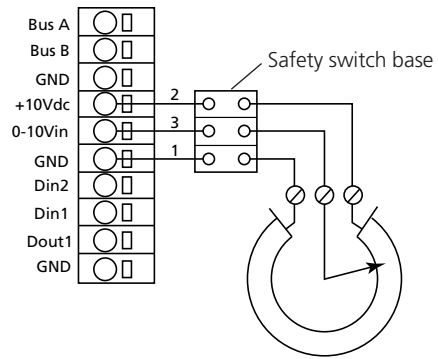

Figure 3

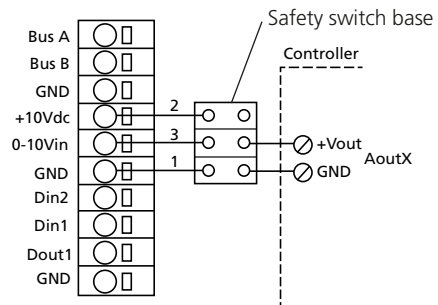

Figure 4

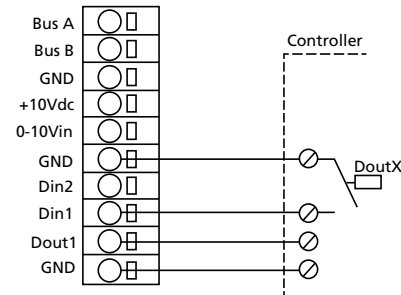
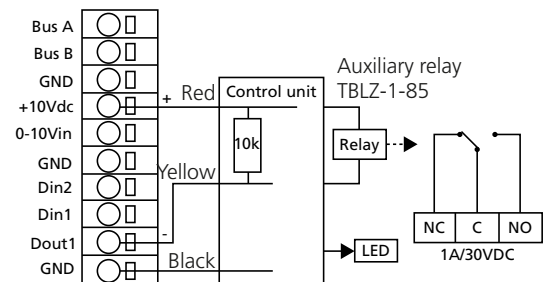

Figure 5.



The relay is drawn in the deenergized state. In the event of an alarm, the relay switches and makes between C and NO.

## 5. Commissioning/Operation



### Warning

Make sure that any contact guards and motor protection housing/side panels are fitted. Risk of personal injury!

The power roof ventilator is designed for continuous operation.

1. Check that there are no foreign objects inside the power roof ventilator or duct system.
2. Check the function of all connected regulation devices.
3. Start the power roof ventilator by switching on the safety isolating switch.

## 6. Measurement of the airflow

Air flow measurement is performed by reading the manometer/pressure gauge.

There is a measurement nipple fitted on the side of the power roof ventilator and this is connected to the minus (-) on the measurement device. There is a measurement nipple fitted on extract air duct (not Swegon) and this is connected to the plus (+) on the measurement device.

Note that, at the roof penetration collar or insulated duct, the measurement nipple must be long enough so that the measurement point is in the duct.

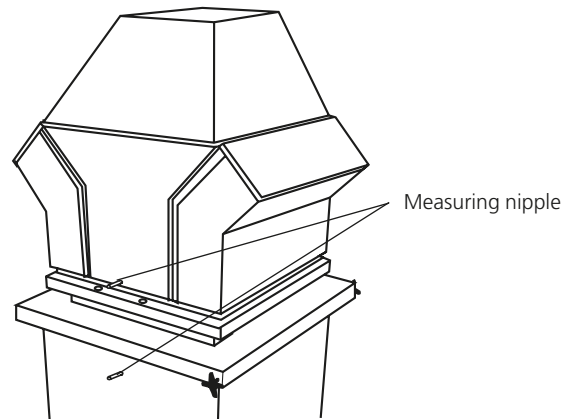

The read pressure is converted to air flow with the help of the following formula:

$$q = K \times 1.29 \times \sqrt{\Delta p}$$

$q$  = Air flow at the fan's inlet ( $m^3/h$ )  
 $K$  = K-factor, depending on the fan size ( $m^2/s/h$ ), see the table below.  
 $\Delta p$  = Pressure measured at the fan's inlet (Pa)

The formula applies at air temperature 20 °C. At other temperatures, correct the pressure according to:

$$\Delta p_{flow} = \Delta p_{read} \times \frac{273 + t}{293}$$

$t$  = Current air temperature in °C

Table K-factor

MIRU	K-factor (COP)
-3-25-28-1-1	66
-3-25-31-1-1	84
-3-35-35-1-1	106
-3-35-40-1-1	136
-3-35-45-1-1	158
-3-45-50-1-1	197
-3-45-56-1-1	247
-3-45-56-2-1	247
-3-56-63-1-1	334
-3-56-71-1-2	415
-3-71-80-1-2	476
-3-71-80-2-2	476
-3-71-90-1-2	605

## 7. Maintenance

### Warning

Follow the safety instructions in section 2.

#### 7.1 Preparations before maintenance

1. Switch off the safety isolating switch.
2. Wait until the fan has stopped rotating.
3. Wait until all hot surfaces have cooled.
4. Remove any dirt from the power roof ventilator's casing.

#### 7.2 Accessibility

The power roof ventilator can be raised for inspection and maintenance. All power roof ventilators have a built-in mechanism for raising on hinges, see section 7.2.2. If Swegon's connecting sleeve or roof penetration collar is fitted, power roof ventilators in the size 25–45 can also be raised as set out in section 7.2.1.

#### 7.2.1 Raise/lower the power roof ventilator, size 25–45, med Swegon's connecting sleeve/roof penetration collar

### Warning

 Make sure the power roof ventilator does not suddenly move back to the raised position. Risk of personal injury!

#### Raise the power roof ventilator

Unscrew the locking screws on the connecting sleeve, see diagram below. Raise the power roof ventilator. In order to prevent the power roof ventilator from tipping over, it is secured by means of a chain/wire or internal stays from the roof penetration collar to the connecting sleeve. If there are internal stays, these are locked in the intended slots.

#### Lower the power roof ventilator

Loosen the stay from the roof penetration collar to the connecting sleeve if applicable. Carefully lower the power roof ventilator. Tighten the locking screws, see diagram below.

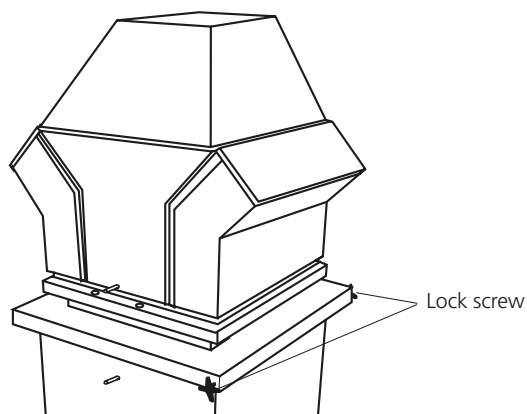

#### 7.2.2 Raise/lower the power roof ventilator, others

### Warning

Make sure the power roof ventilator does not suddenly move back to the raised position. Risk of personal injury!

#### Raise the power roof ventilator

Remove the side piece and motor protection housing. See diagram below.

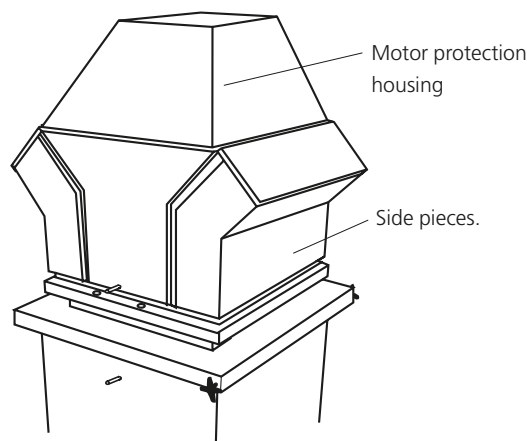

Loosen the locking screws and raise the power roof ventilator. Lock the power roof ventilator by fitting the locking screws in the joint. See diagram below.

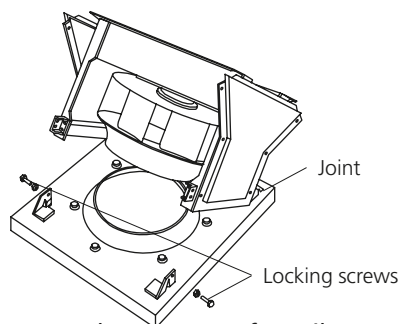

#### Lower the power roof ventilator

Loosen the locking screws in the joint. Carefully lower the power roof ventilator. Fit the locking screws in the original position.

## 8. Dimensions and weight

### 8.1 MIRUVENT power roof ventilator

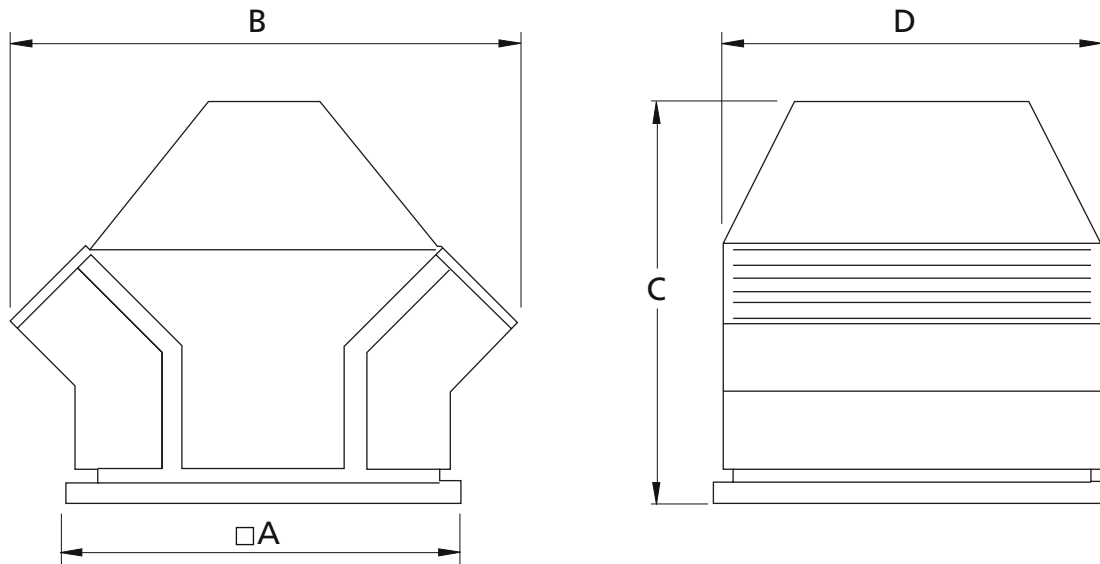

MIRU	A	B	C	D	kg
-3-25-28-1-1	440	600	543	440	26
-3-25-31-1-1	440	600	543	440	26
-3-35-35-1-1	600	770	635	570	37
-3-35-40-1-1	600	770	635	570	38
-3-35-45-1-1	600	770	635	570	39
-3-45-50-1-1	750	985	775	730	50
-3-45-56-1-1	750	985	775	730	61
-3-45-56-2-1	750	985	775	730	61
-3-56-63-1-1	940	1125	946	920	120
-3-56-71-1-2	940	1125	946	920	143
-3-71-80-1-2	1270	1625	1195	1230	260
-3-71-80-2-2	1270	1625	1195	1230	260
-3-71-90-1-2	1270	1625	1195	1230	312

## 8.2 TBFT roof penetration collar

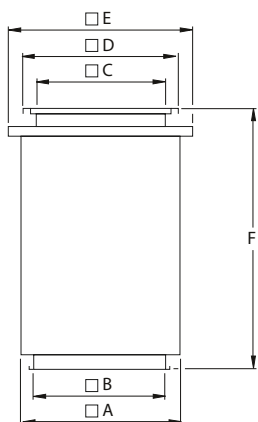

Size	A	B		C	D	E	F	kg	
		EI30	EI60					EI30	EI60
25	505	400	300	360	433	600/610	800	32	40
35	605	500	400	490	593	700/710	800	39	46
45	805	700	600	640	743	900/910	800	53	65
56	905	800	700	830	933	1010	800	58	72
71	1105	1000	900	1000	1243	1200	800	73	92

## 9.3 TBFS connecting sleeve

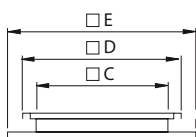

Size	C	D	E	kg
25	360	433	600	11
35	490	593	700	13
45	640	743	900	18
56	830	933	1000	18
71	1000	1243	1200	25